

# Computer Architecture

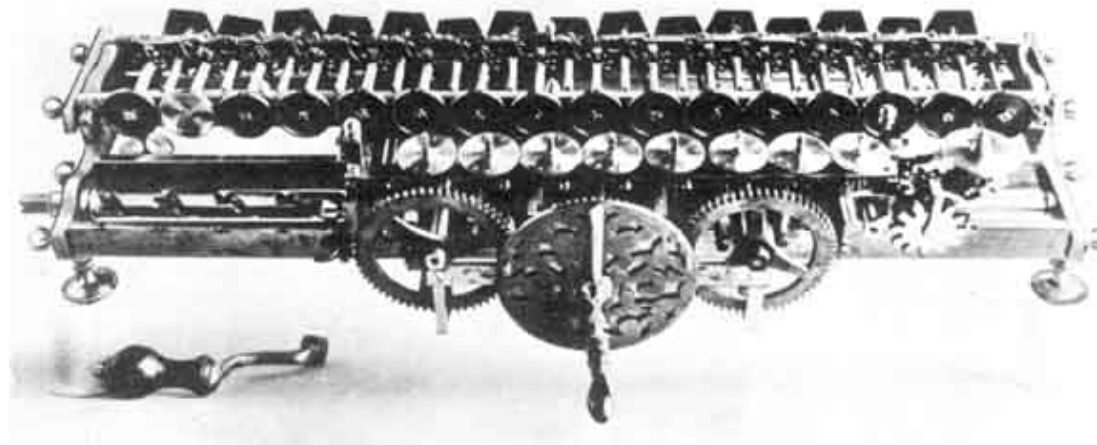

# Babbage's Analytical Engine (1835)

---

- "We may say most aptly that the Analytical Engine weaves algebraic patterns just as the Jacquard-loom weaves flowers and leaves" (Ada Lovelace)

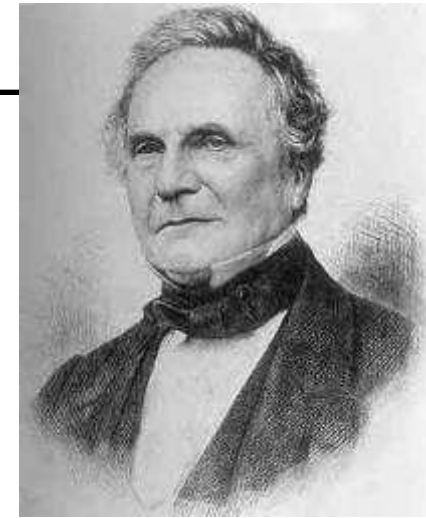

Charles Babbage (1791-1871)

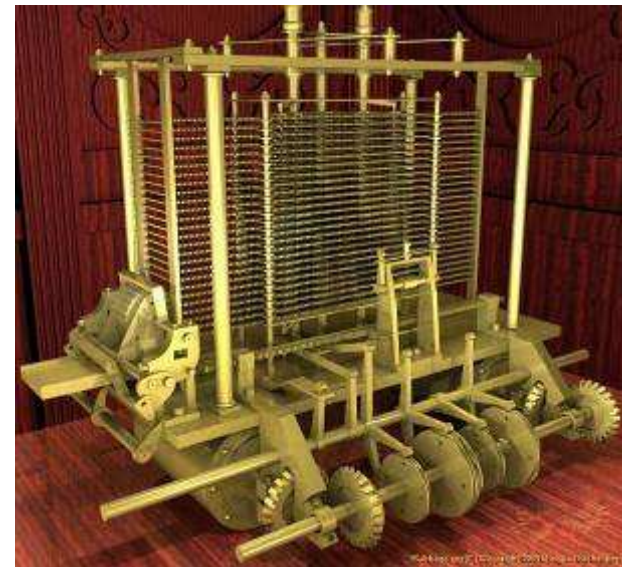
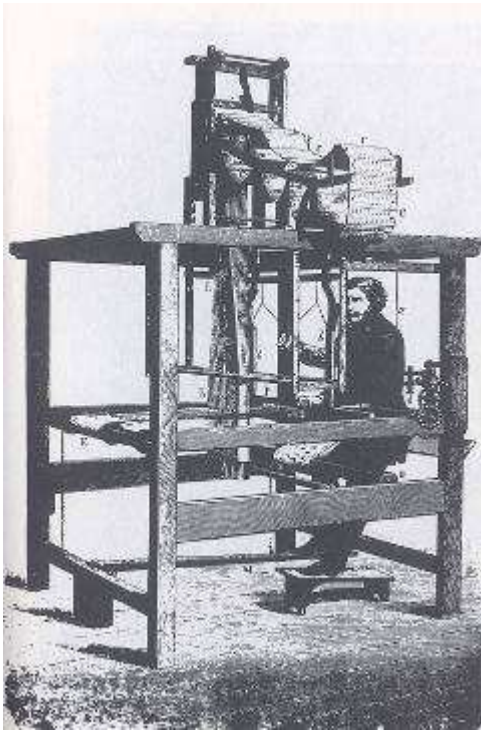

## Other early computers and “computer scientists”

---



**Blaise Pascal**  
1623-1662

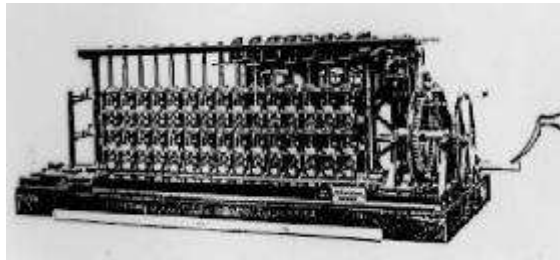

**Gottfried Leibniz**  
1646-1716

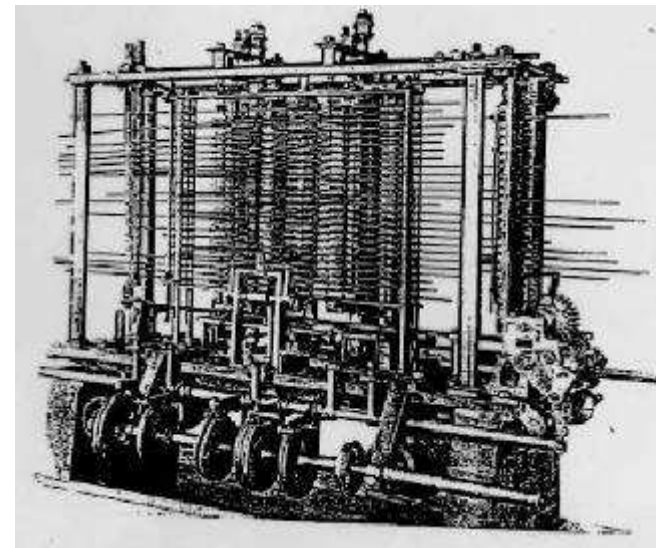
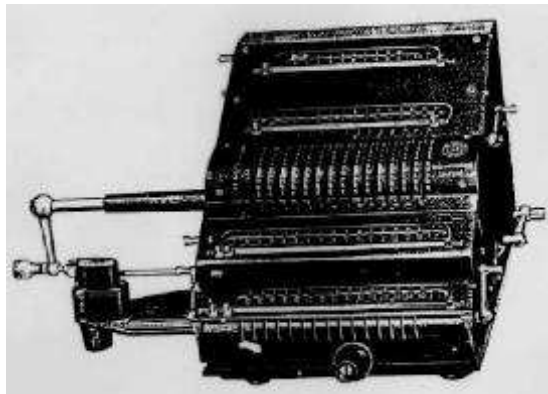

# Von Neumann machine (c. 1940)

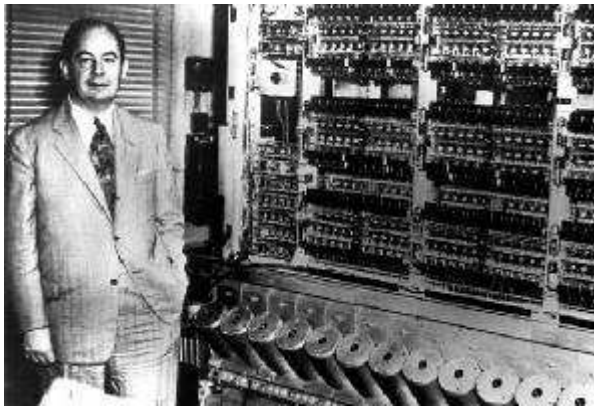
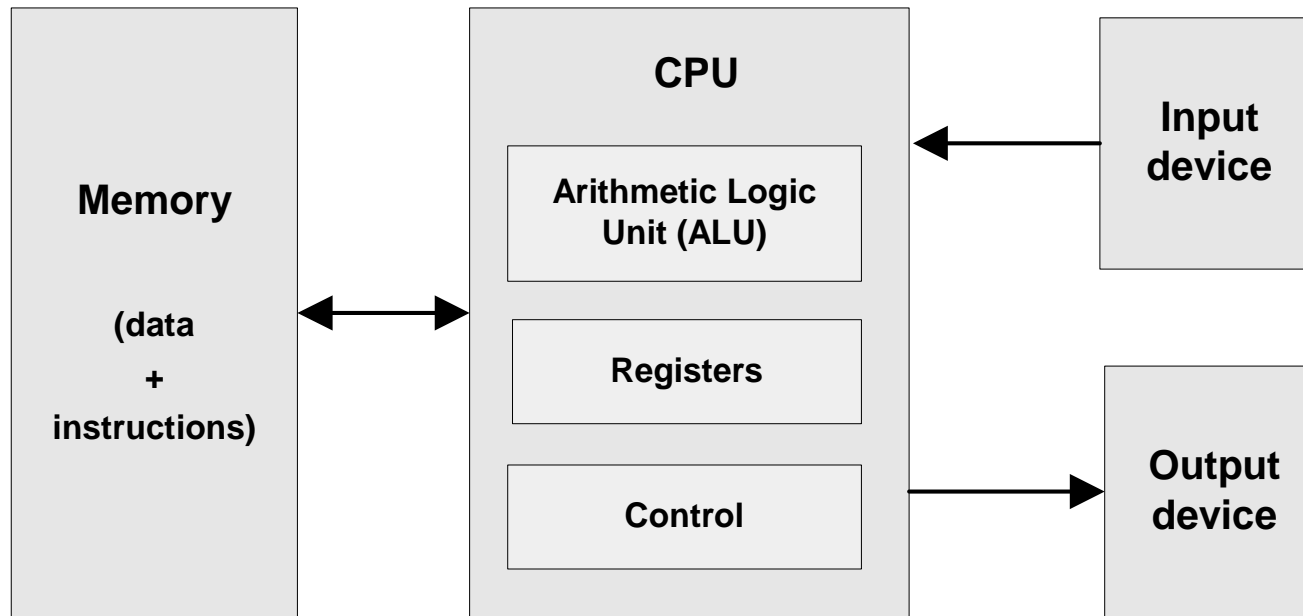

*John Von Neumann (and others) ... made it possible*

Stored  
program  
concept!



*Andy Grove (and others) ... made it small and fast.*

# Processing logic: fetch-execute cycle

---

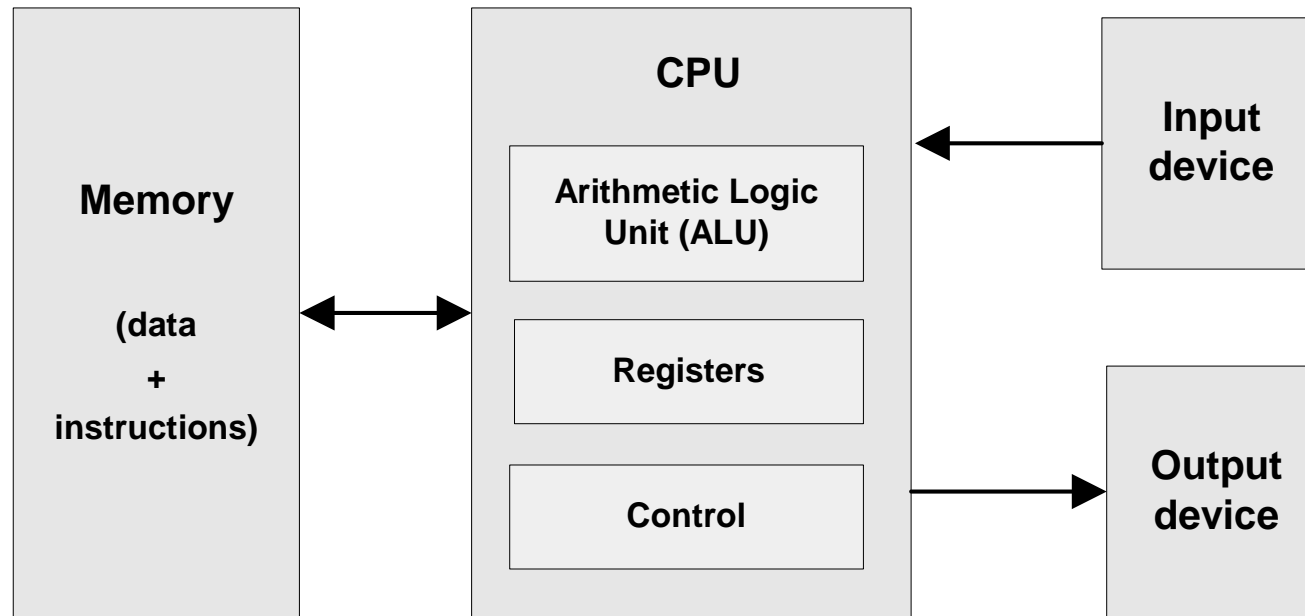

Executing the *current instruction* involves one or more of the following micro tasks:

- Have the ALU compute some function  $f(\text{registers})$
- Write the ALU output to selected register(s)
- As a side-effect of executing these tasks, figure out which instruction to fetch and execute next.

# The Hack chip-set and hardware platform

---

## Elementary logic gates

- Nand
- Not
- And
- Or
- Xor
- Mux
- Dmux
- Not16
- And16
- Or16
- Mux16
- Or8Way
- Mux4Way16
- Mux8Way16
- DMux4Way
- DMux8Way

done

## Combinational chips

- HalfAdder
- FullAdder
- Add16
- Inc16
- ALU

done

## Sequential chips

- DFF
- Bit
- Register
- RAM8
- RAM64
- RAM512
- RAM4K
- RAM16K
- PC

done

## Computer Architecture

- Memory
- CPU
- Computer

this lecture

# The Hack computer

---

- 16-bit Von Neumann platform
- *Instruction memory* and *data memory* are physically separate
- I/O: 512 by 256 black and white screen, standard keyboard
- Designed to execute programs written in the Hack machine language
- Can be easily built from the chip-set that we built so far in the course

## Main parts of the Hack computer:

- Instruction memory
- Memory:
  - Data memory
  - Screen
  - Keyboard
- CPU
- Computer (the glue that holds everything together).

# Lecture plan

---

- Instruction memory
- Memory:
  - Data memory
  - Screen
  - Keyboard
- CPU
- Computer

# Instruction memory

---

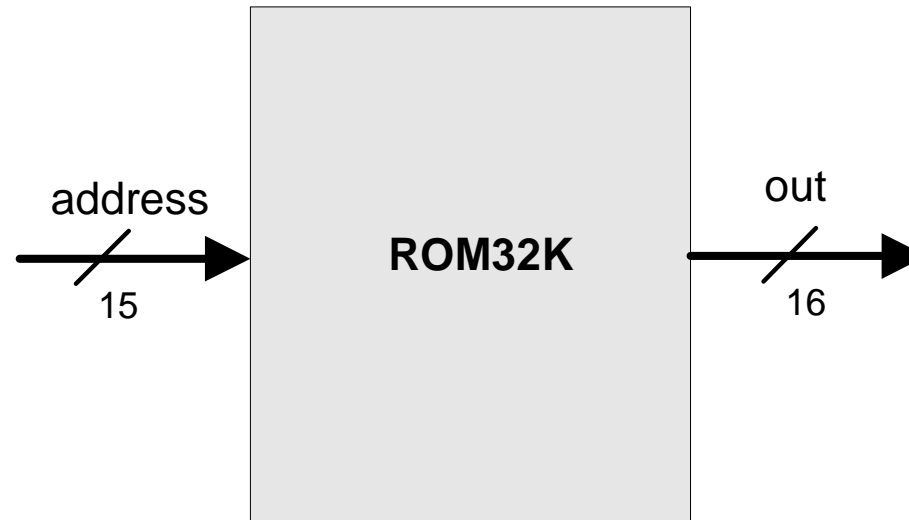

## Function:

- Pre-loaded with a machine language program
- Always emits a 16-bit number:

`out = ROM32K[address]`

- This number is interpreted as the *current instruction*.

# Data memory

---

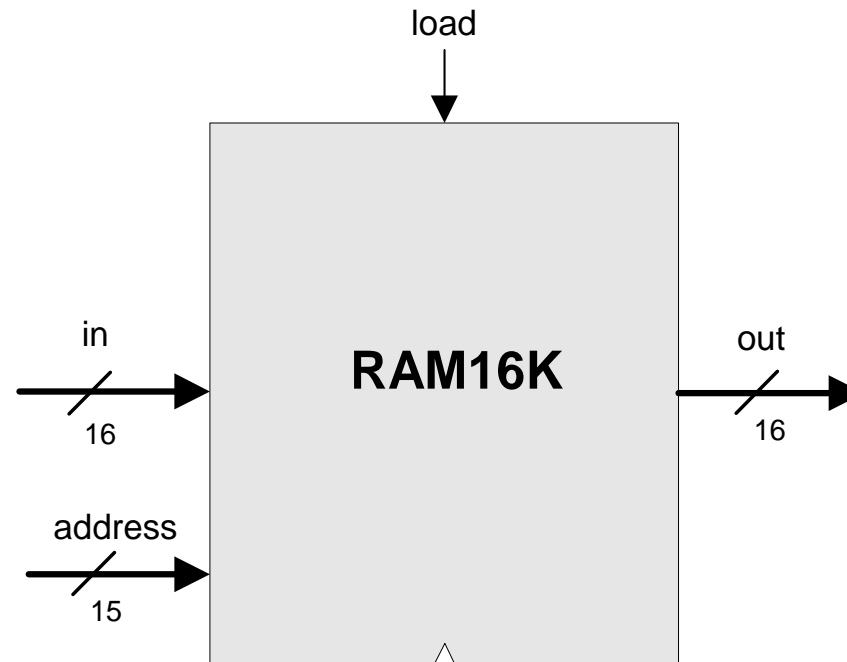

## Reading/writing logic

- Low level: Set **address**, **in**, **load** ; probe **out**
- Higher level (e.g. OS level): **peek (address)**  
**poke (address , value) .**

# Lecture plan

---

- ✓ ■ Instruction memory
- Memory:
  - ✓ ● Data memory
  - Screen
  - Keyboard
- CPU
- Computer

# Screen

---

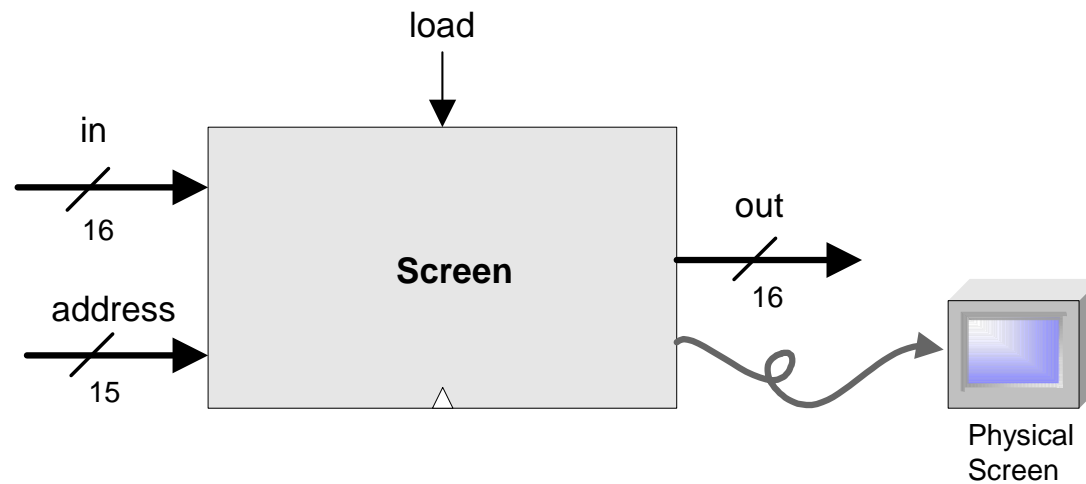

- Functions exactly like a 16-bit 8K RAM :
  - `out = Screen[address]`
  - `If load then Screen[address] = in`
- Side effect:  
continuously refreshes a 256 by 512 black-and-white screen.

# Screen memory map

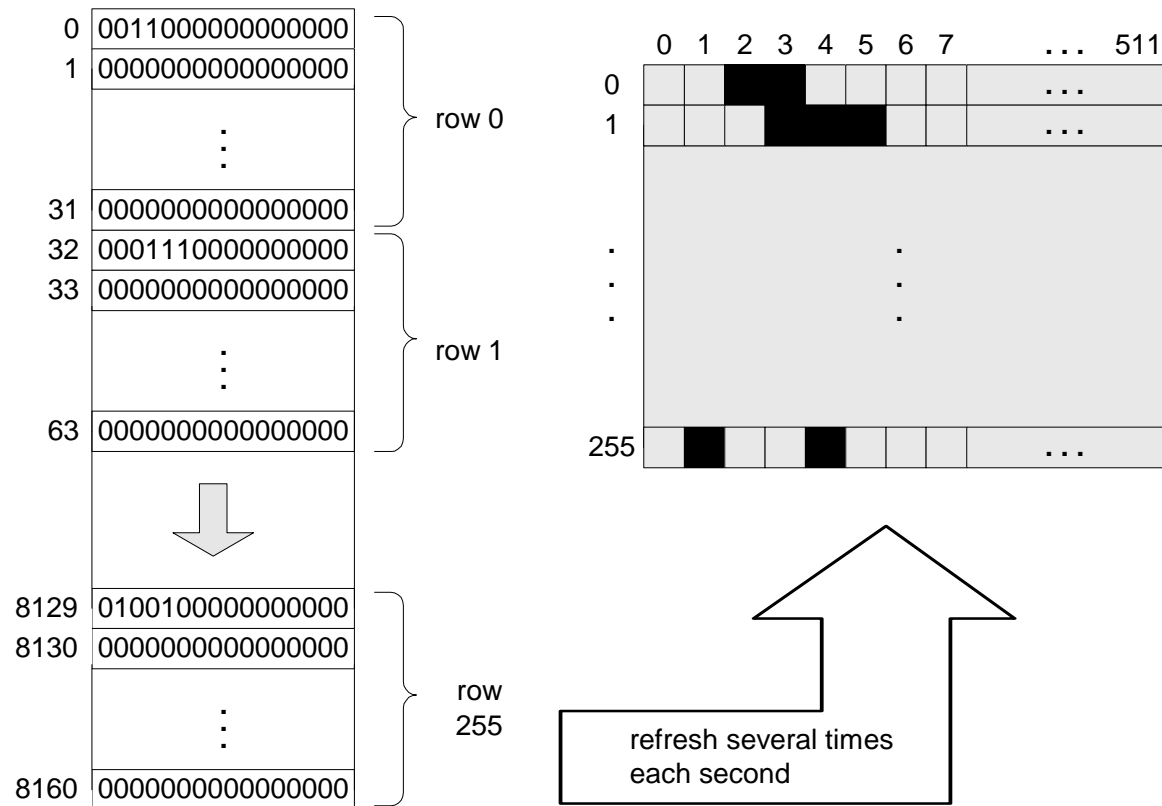
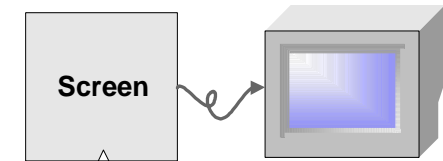

## Writing `pixel(x,y)` to the screen:

- Low level: Set the  $y\%16$  bit of the word found at `Screen[x*32+y/16]`
- High level: Use `drawPixel(x,y)` (OS service, later).

# Keyboard

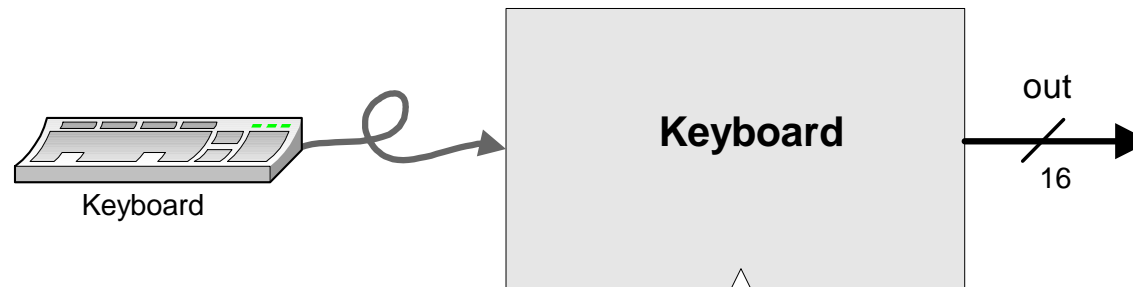

- Keyboard chip = 16-bit register
- Input: 16-bit value coming from a physical keyboard
- Output: the scan code of the pressed key, or 0 if no key is pressed
- Special keys:

Key pressed	Keyboard output	Key pressed	Keyboard output
newline	128	end	135
backspace	129	page up	136
left arrow	130	page down	137
up arrow	131	insert	138
right arrow	132	delete	139
down arrow	133	esc	140
home	134	f1-f12	141-152

## Reading the keyboard:

- Low level: probe the contents of the `Keyboard` register
- High level: use `keyPressed()` (OS service, later).

# The Hack computer

---

- ✓ ■ Instruction memory
- Memory:
  - ✓ ● Data memory
  - ✓ ● Screen
  - ✓ ● Keyboard
- CPU
- Computer

# Memory

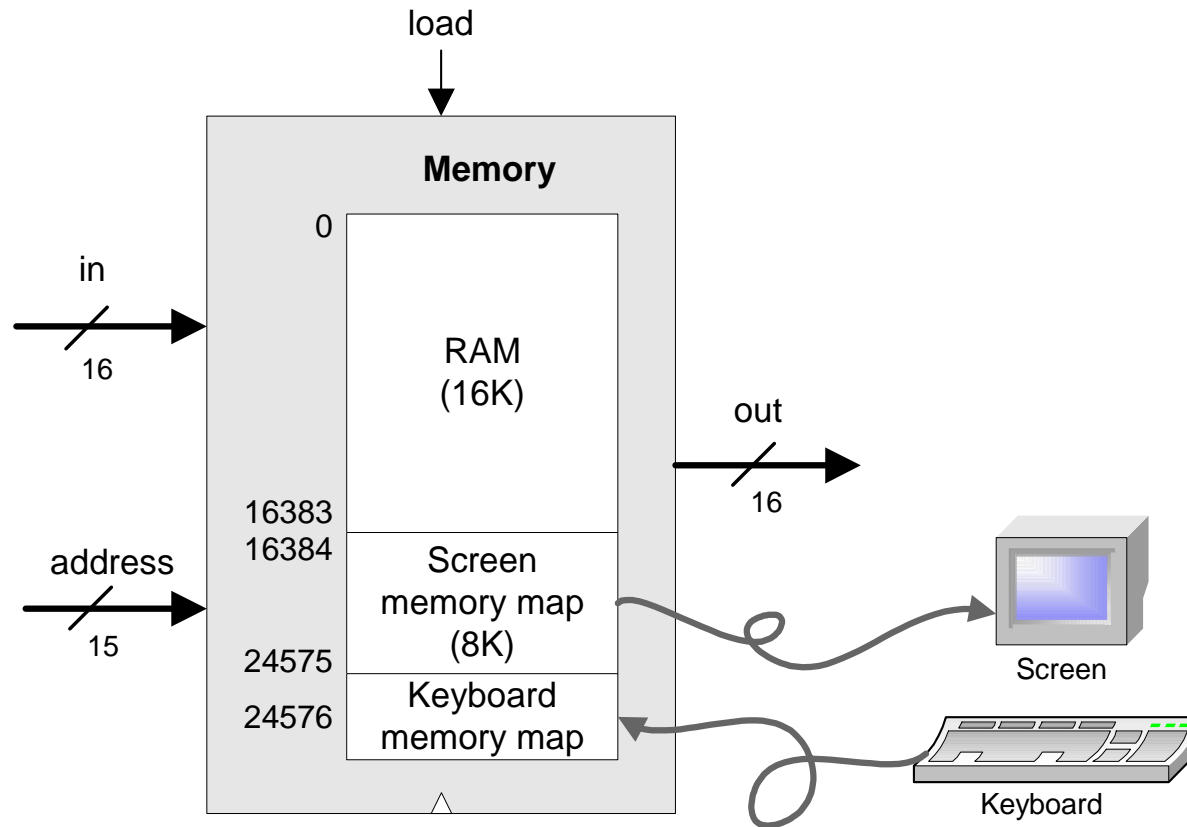

## Function:

- Access to any address from 0 to 16,383 results in accessing the **RAM**
- Access to any address from 16,384 to 24,575 results in accessing the **Screen** memory map
- Access to address 24,576 results in accessing the **keyboard** memory map
- Access to any address  $> 24576$  is invalid.

# The Hack computer

---

- ✓ ■ Instruction memory
- ✓ ■ Memory:
  - ✓ ● Data memory
  - ✓ ● Screen
  - ✓ ● Keyboard
- CPU
- Computer

## A pledge to patience

---

"At times ... the fragments that I lay out for your inspection may seem not to fit well together, as if they were stray pieces from separate puzzles. In such cases, I would counsel patience. There are moments when a large enough fragment can become a low wall, a second fragment another wall to be raised at a right angle to the first. A few struts and beams later, and we may have made ourselves a rough foundation ... But it can consume the better part of a chapter to build such a foundation; and as we do so the fragment that we are examining may seem unconnected to the larger whole. Only when we step back can we see that we have been assembling something that can stand in the wind."

From:

Sailing the Wind Dark Sea (Thomas Cahill)



# CPU

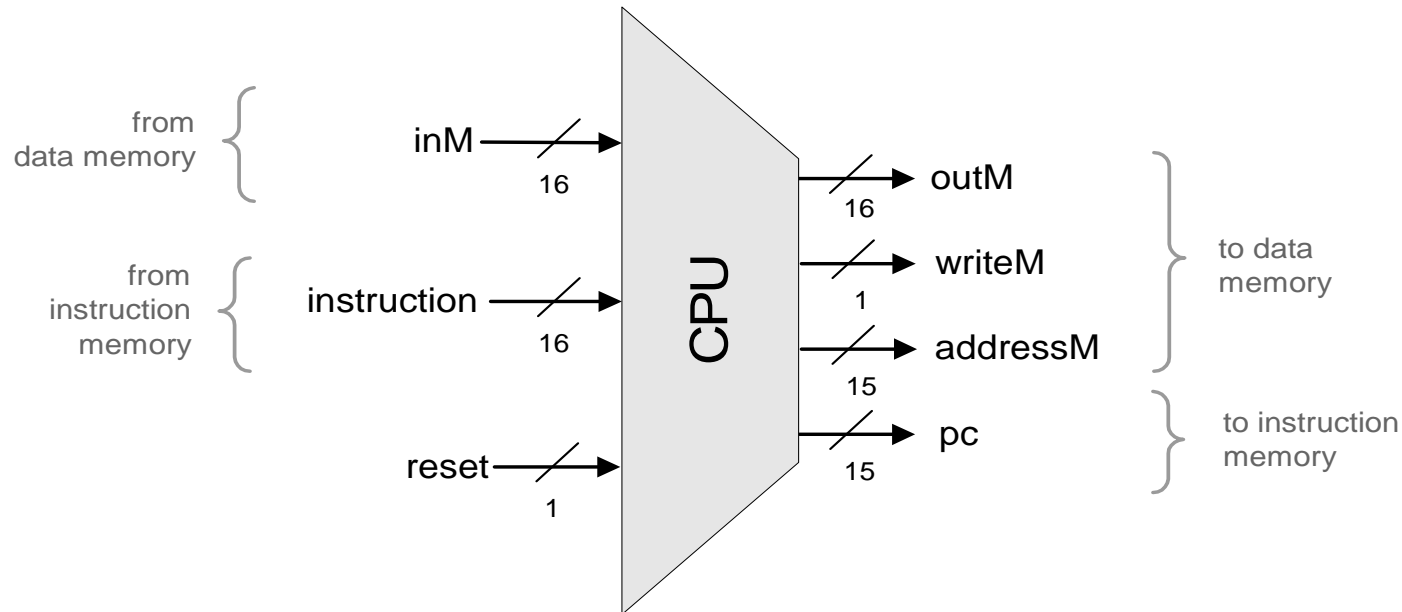

CPU components: **ALU** + **A**, **D**, **PC** registers

CPU Function: Executes the **instruction** according to the Hack language specification:

- The **M** value is read from **inM**
- The **D** and **A** values are read from (or written to) these CPU-resident registers
- If the instruction wants to write to **M** (e.g. **M=D**), then the **M** value is placed in **outM**, the value of the CPU-resident **A** register is placed in **addressM**, and **writeM** is asserted
- If **reset=1**, then **pc** is set to 0;  
Otherwise, **pc** is set to the address resulting from executing the current instruction.

# CPU

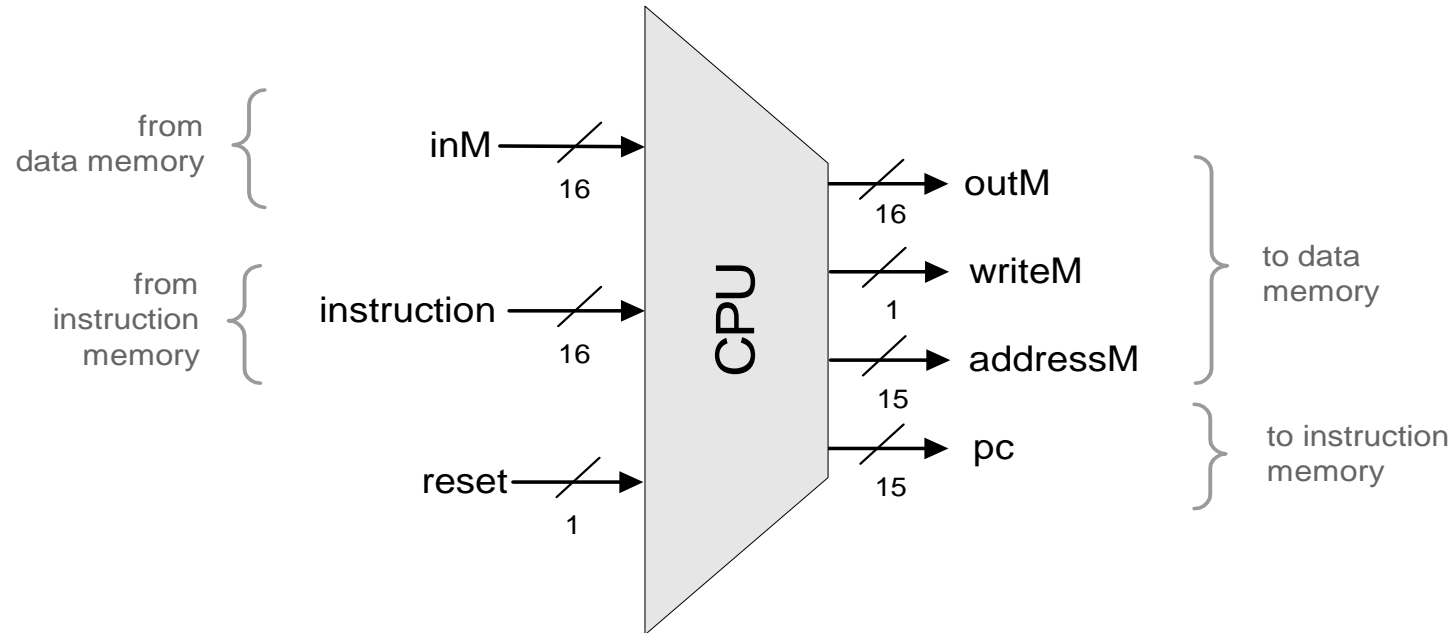

```
CHIP CPU {  
  IN  inM[16], instruction[16], reset;  
  OUT outM[16], writeM, addressM[15], pc[15];  
  PARTS:  
    // Implementation missing  
}
```

■ CPU implementation: next 3 slides.

# The C-instruction revisited

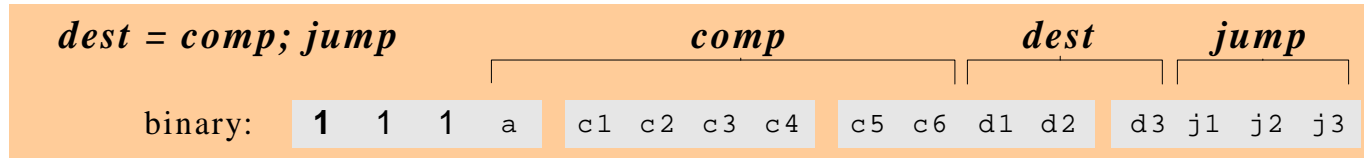

(when a=0) <i>comp</i>	c1	c2	c3	c4	c5	c6	(when a=1) <i>comp</i>	d1	d2	d3	Mnemonic	Destination (where to store the computed value)
0	1	0	1	0	1	0		0	0	0	null	The value is not stored anywhere
1	1	1	1	1	1	1		0	0	1	M	Memory[A] (memory register addressed by A)
-1	1	1	1	0	1	0		0	1	0	D	D register
D	0	0	1	1	0	0		0	1	1	MD	Memory[A] and D register
A	1	1	0	0	0	0	M	1	0	0	A	A register
!D	0	0	1	1	0	1		1	0	1	AM	A register and Memory[A]
!A	1	1	0	0	0	1	!M	1	1	0	AD	A register and D register
-D	0	0	1	1	1	1		1	1	1	AMD	A register, Memory[A], and D register
-A	1	1	0	0	1	1	-M					
D+1	0	1	1	1	1	1			j1	j2	j3	
A+1	1	1	0	1	1	1	M+1	(out < 0)	(out = 0)	(out > 0)	Mnemonic	Effect
D-1	0	0	1	1	1	0		0	0	0	null	No jump
A-1	1	1	0	0	1	0	M-1	0	0	1	JGT	If out > 0 jump
D+A	0	0	0	0	1	0	D+M	0	1	0	JEQ	If out = 0 jump
D-A	0	1	0	0	1	1	D-M	0	1	1	JGE	If out ≥ 0 jump
A-D	0	0	0	1	1	1	M-D	1	0	0	JLT	If out < 0 jump
D&A	0	0	0	0	0	0	D&M	1	0	1	JNE	If out ≠ 0 jump
D A	0	1	0	1	0	1	D M	1	1	0	JLE	If out ≤ 0 jump
								1	1	1	JMP	Jump

# CPU implementation

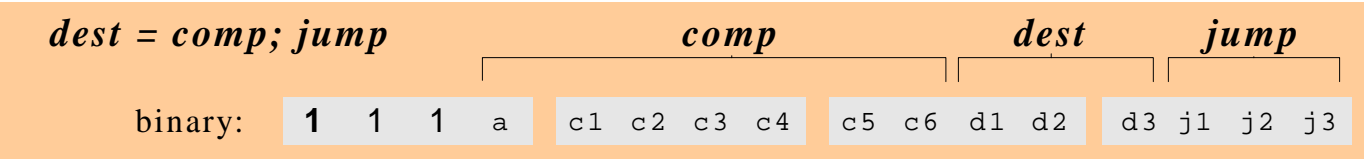

## Chip diagram:

- Includes most of the exec. logic
- Control logic is hinted.

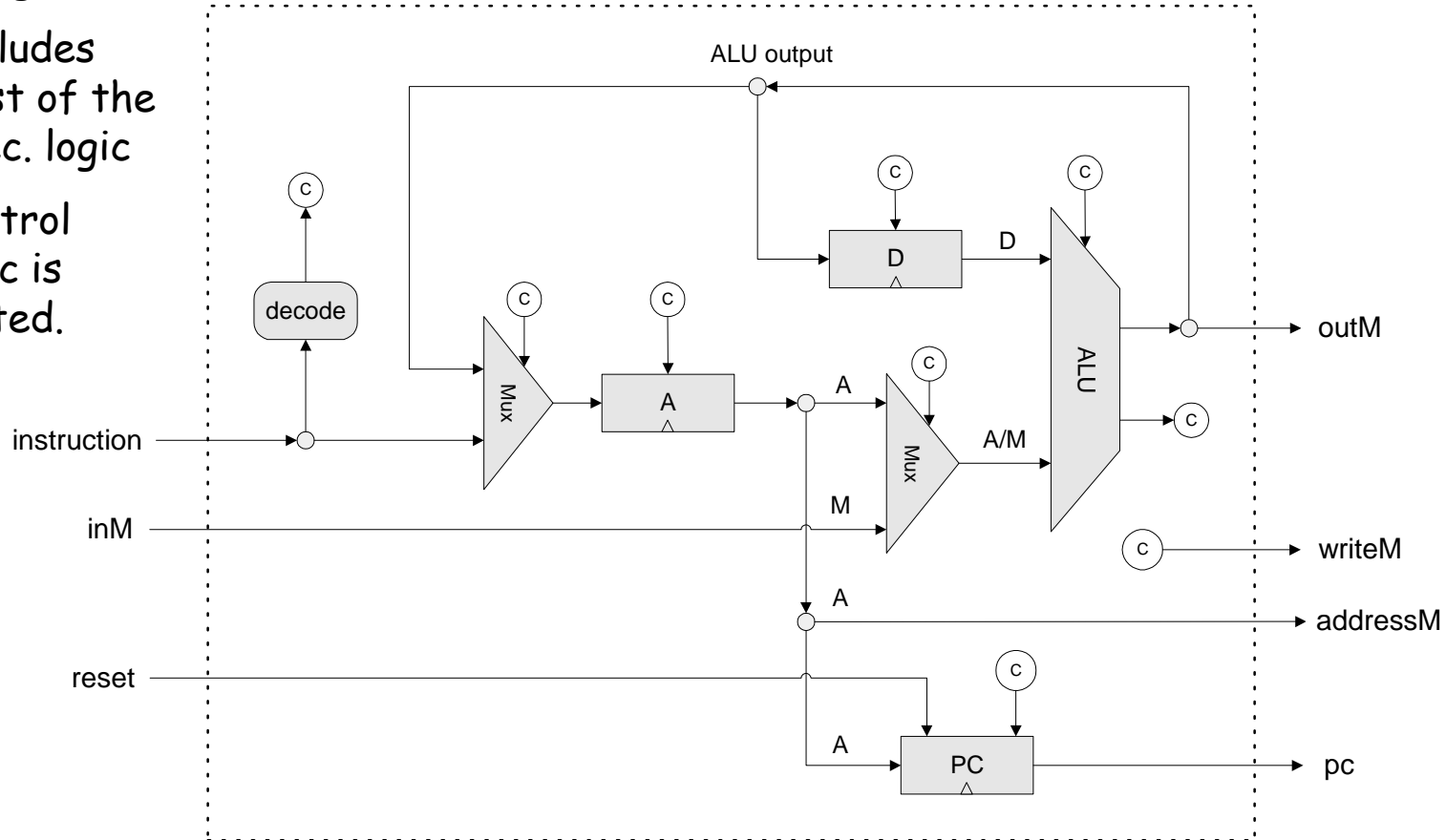

### Cycle:

- Fetch
- Execute

### Execute logic:

- Decode
- Execute

### Fetch logic:

If jump then set **PC** to **A**  
else set **PC** to **PC+1**

### Reset logic:

Set **reset** to 1,  
then to 0.

# The Hack computer

---

- ✓ ■ Instruction memory
- ✓ ■ Memory:
  - ✓ ● Data memory
  - ✓ ● Screen
  - ✓ ● Keyboard
- ✓ ■ CPU
- Computer

# Computer-on-a-chip interface

---

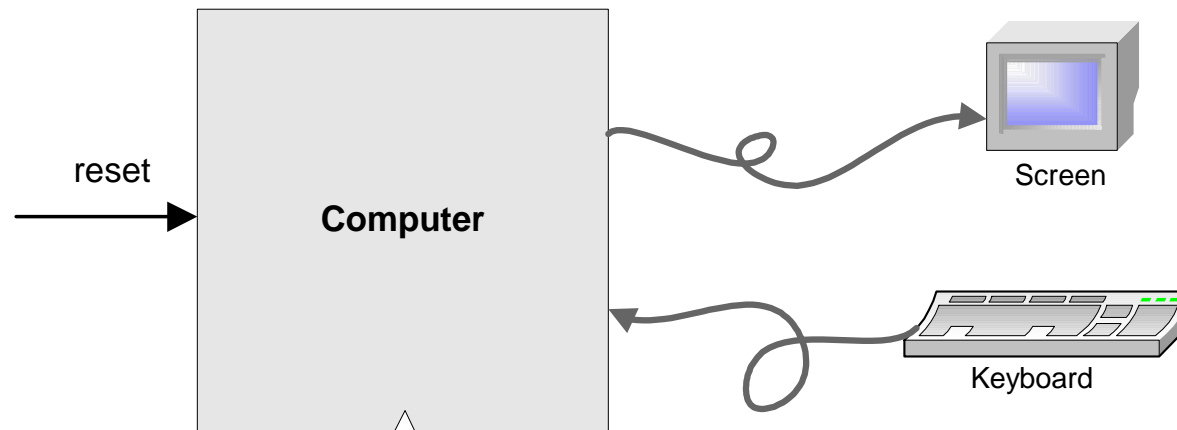

```
Chip Name: Computer // Topmost chip in the Hack platform
Input:      reset
Function:  When reset is 0, the program stored in the
               computer's ROM executes. When reset is 1, the
               execution of the program restarts. Thus, to start a
               program's execution, reset must be pushed "up" (1)
               and "down" (0).
```

From this point onward the user is at the mercy of the software. In particular, depending on the program's code, the screen may show some output and the user may be able to interact with the computer via the keyboard.

# Computer-on-a-chip implementation

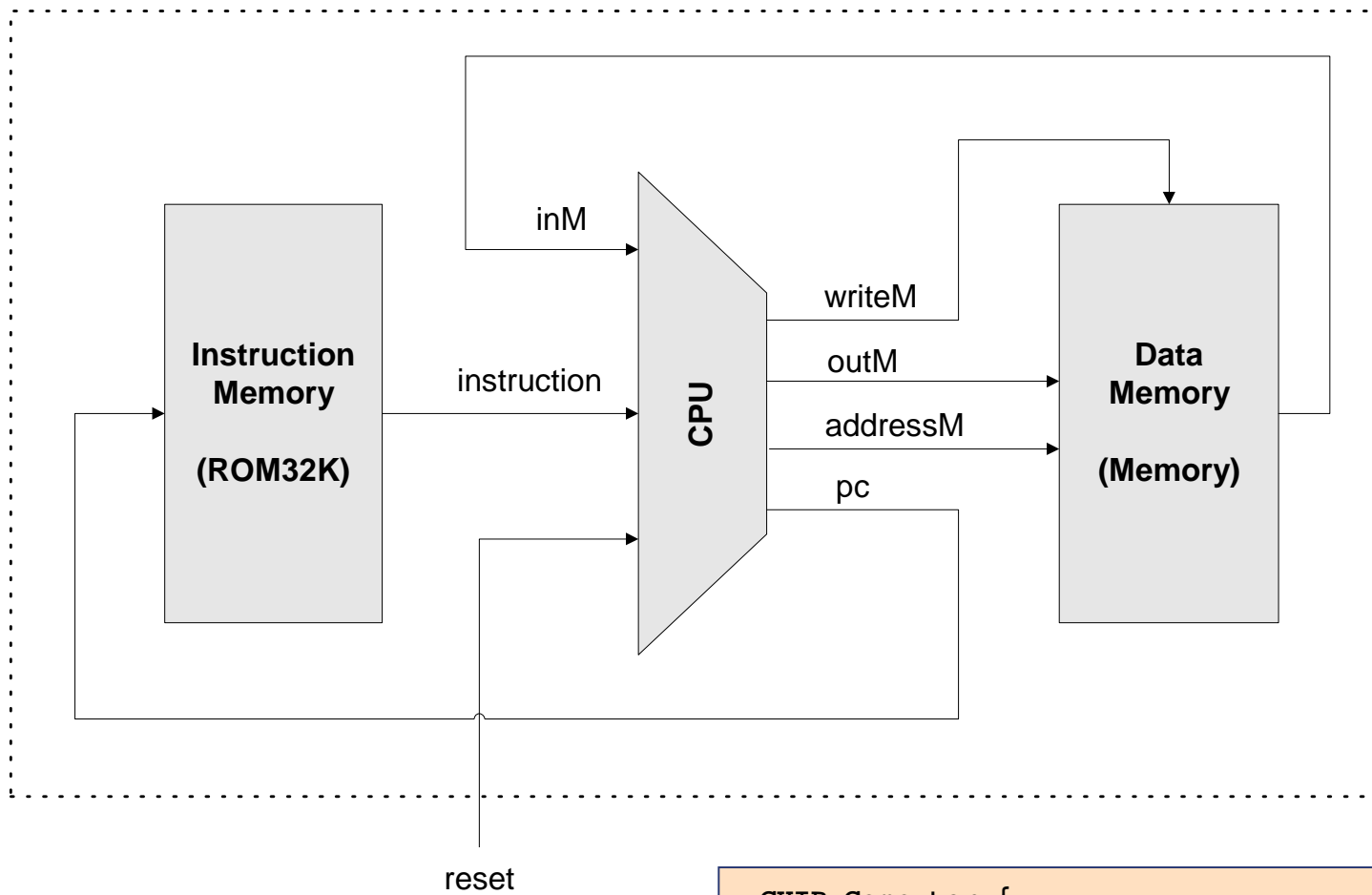

```
CHIP Computer {  
    IN reset;  
    PARTS:  
        // implementation missing  
}
```

# The Big Picture

---



- ✓ ■ Instruction memory
- ✓ ■ Memory:
  - ✓ ● Data memory
  - ✓ ● Screen
  - ✓ ● Keyboard
- ✓ ■ CPU
- ✓ ■ Computer

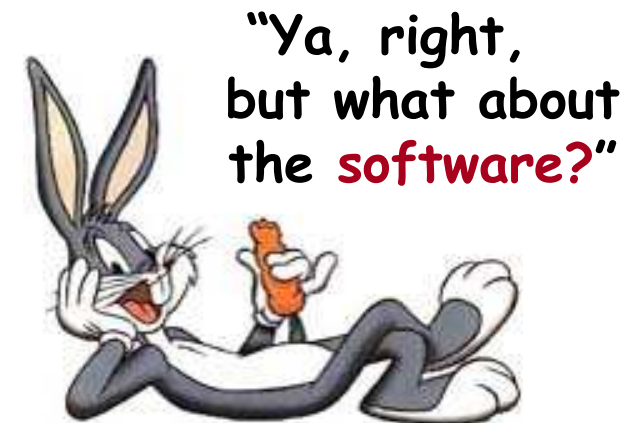

# How it actually looks (thank goodness for abstractions!)

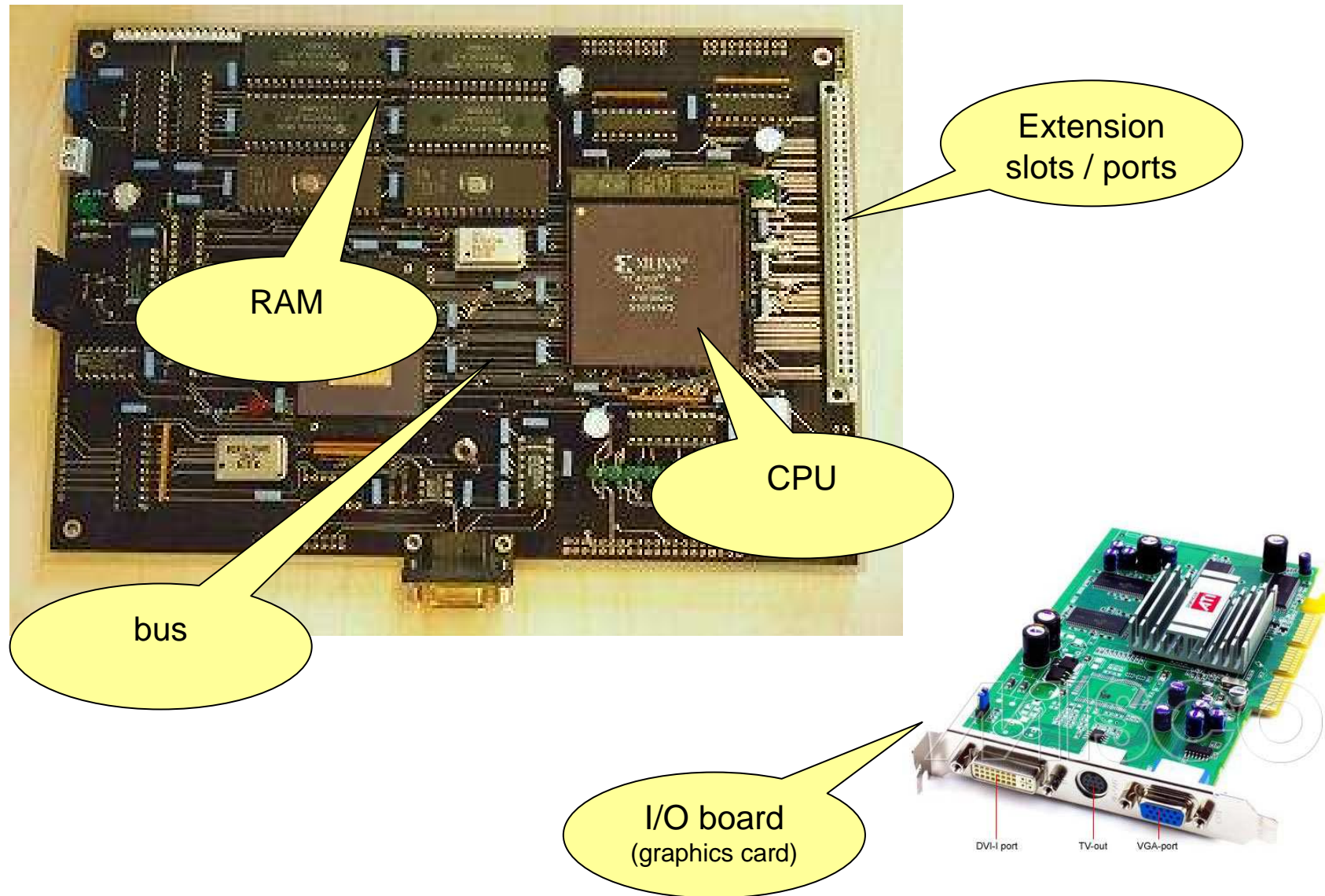

# Perspective

---

- I/O: more units, processors
- Special-purpose processors (graphics, communications, ...)
- Efficiency
- CISC / RISC (HW/SW trade-off)
- Diversity: desktop, laptop, hand-held, game machines, ...
- General-purpose VS dedicated / embedded computers
- Silicon compilers
- And more ...